

GALFER

INSTRUCTIONS FOR INSTALLING GALFER BRAKE LINE KIT 2001~ 2006 HONDA GOLDWING 1800A

310 Irving Dr Oxnard, CA 93033

Galfer Tech: 1-800-685-6633

tech@galferusa.com

Thank you for purchasing Galfer lines. In order to get the maximum performance and enjoyment out of your Galfer lines, please read the instructions thoroughly before you begin installation.

Must have items:

Torque wrench, line wrenches, a commercial available vacuum/pressure bleeder for brake systems, replacement DOT 4 brake fluid (two 500cc bottles needed), shop towels, and a general assortment of metric tools.

NOTE: THIS IS A TIME CONSUMING TASK REQUIRING KNOWLEDGE OF THE MOTORCYCLE'S BRAKE SYSTEM, MECHANICAL ABILITY, AND THE USE AND OPERATION OF SPECIALIZED TOOLS. HAVING THE FACTORY HONDA SERVICE MANUAL FOR THIS MOTORCYCLE IS NEEDED.

PREP THE MOTORCYCLE FOR THIS JOB



Brake Harder, Brake Later, Brake Galfer

- Available in 8 Colors
- 16 Strands of Steel Braid
- Dash 2.8 mm Dupont Teflon Hose
- Includes New Banjo Bolts & Washers
- Reduces Fade & Gives Improved Modulation

Quality Above All Else, Lifetime Warranty

(Fig:MG0033)

Park the motorcycle on the center stand in a well-lit shop

Note: It is absolutely necessary to remove the fuel tank and body panels (see factory manual). Brake fluid is VERY CORROSIVE TO PAINT. Remove the lower fairing left and right rear sides, fuel tank, front fender, seat, and black plastic inner fairing front parts, battery cover, battery, and rear master cylinder cover according to the service manual.



(Fig.MG0033 & MG0035)

After safely storing the body panels and fuel tank, remove wind shield, (brake fluid, even a drop, will permanently mark any clear plastic), cover the dash and all gauges with a towel.



DRAINING THE BRAKE FLUID FROM THE SYSTEMS.

Note:

- A contaminated brake disc or pad reduces stopping power. Discard contaminated disc with a high quality brake degreasing agent.
- Do not allow foreign material to enter the system when filling the reservoir.
- Avoid spilling fluid on painted, plastic or rubber parts. Place a rag over these parts whenever the system is serviced.
- Use only DOT 4 brake fluid from a sealed container.
- Do not mix different types of fluid. They are not compatible.
- Once the hydraulic system has been opened, or if the brake feels spongy, the system must be bled.
- When using a commercially available brake bleeder, follow the manufacture's operating instructions.

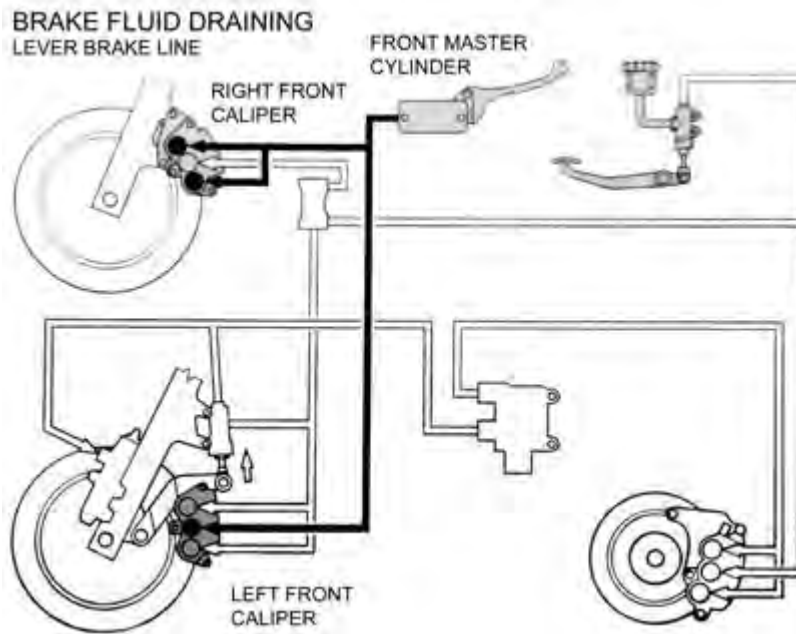

Remove front fender and fender covers. Support the motorcycle on its center stand. Turn the handlebar to the left until the front master cylinder reservoir is level before removing the reservoir cap. Remove the screws, reservoir cap, set plate and diaphragm.



Connect a commercially available brake bleeder to the bleed valve of the front caliper at the position as shown. Loosen the bleed valve and pump the brake bleeder until no more fluid flows out of the bleed valve. Tighten the bleed valve. Perform the above procedure at the other front caliper.



PEDAL BRAKE LINE

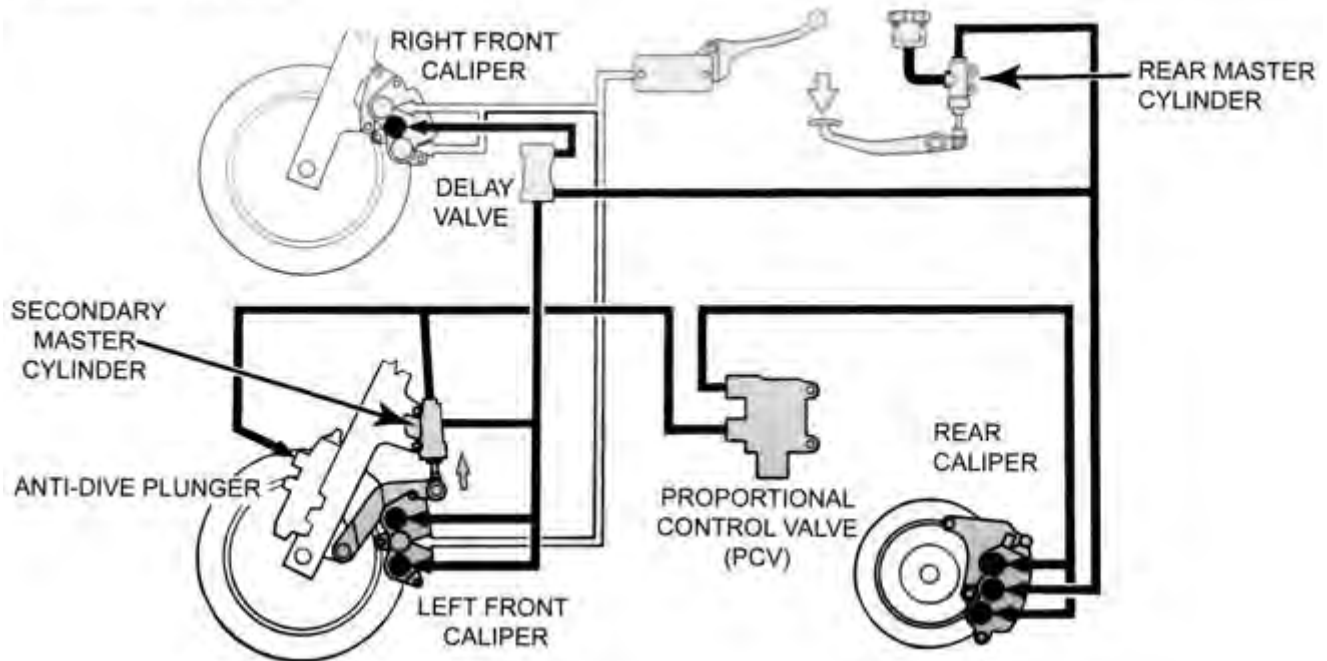

Remove the following:

- Right engine side cover.
- Front fender A and fender covers

Support the motorcycle on its center stand.

Remove the rear master cylinder reservoir cap. As shown on the right. Connect a commercially available brake bleeder to the bleed valve of the front caliper at the position as shown. Loosen the bleed valve and pump the brake bleeder until no more fluid flows out of the bleed valve.

Perform the above procedure at each remaining valve of the brake pedal brake line.

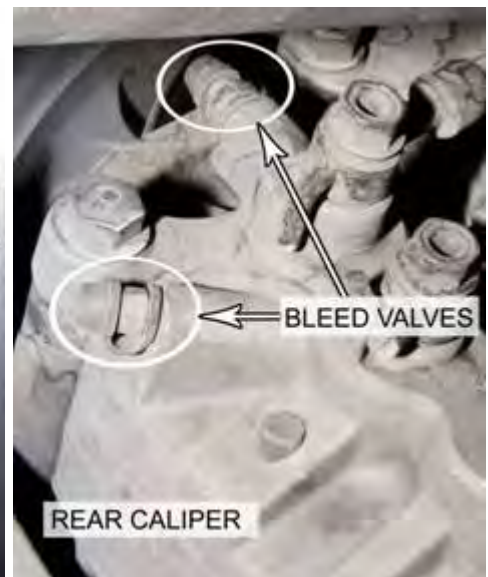
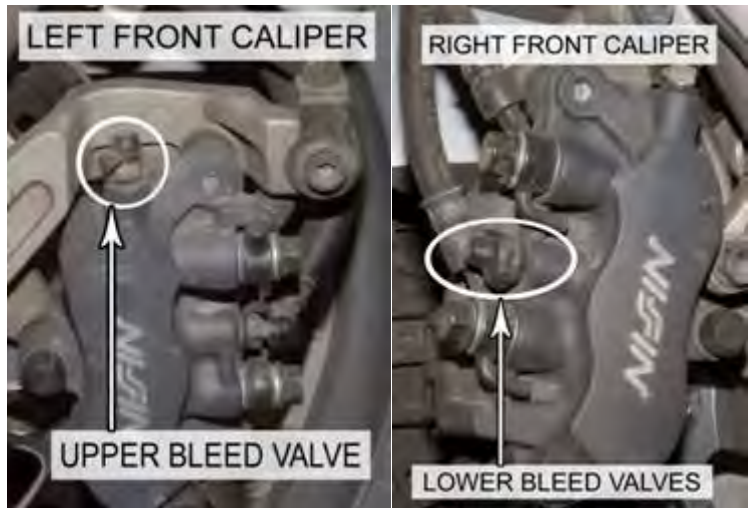

BEGIN INSTALLATION OF NEW BRAKE LINE SYSTEM.

We recommend replacing one line at a time.

Note: Remove brake fluid from the system. (Factory service manual 15-6,7, and 8)

FRONT MASTER CYLINDER

1. Install Line #1 into front master cylinder (MG0008), following stock routing under handle bar cover, across top triple clamp retainers, down to right OEM tubing w/ brass olive. Secure to right front brake hose stay w/ cable tie (MG0009, MG0021)

(Fig: MG0008)
Starting from the Front Master Cylinder (Line# 1) route to very right top OEM tubing.

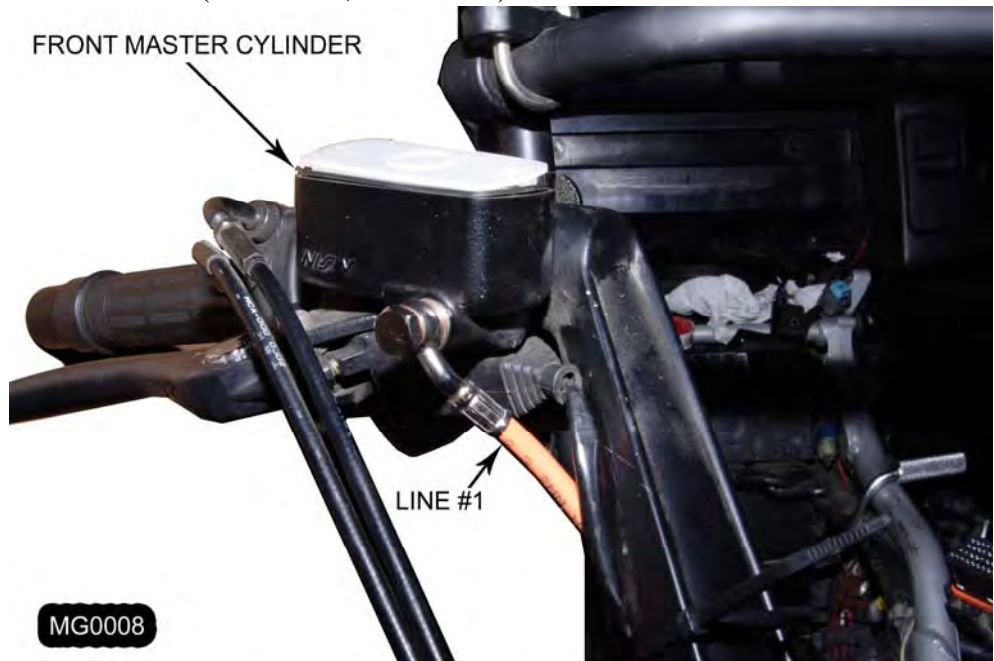

(Fig: MG0009)
Triple tree area.
(Line# 1) Connected to very right top hard pipe with brass olive as shown below.



Note: Use brass olive to OEM tube.

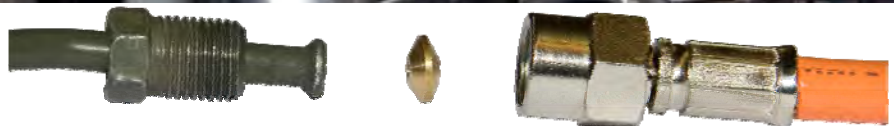

FRONT BRAKE HOSE ASSEMBLY AND ROUTING

Note: Remove “wind protector” (13-42 factory manual), remove brake hose clamps from brake hose clamp stay.

RIGHT HAND SIDE

- 1) Install Line #2 on the (MG0021) into OEM tubing, with brass olive.
Secure to right front brake hose stay with cable tie. Install lower end of Line #2 to top banjo bolt hole of delay valve (MG0025)
- 2) Install Line #3 into OEM tubing with brass olive (MG0027). Install lower end Line #3 into new Galfer T-block (MG0025), use mounting bolt from stock block.
- 3) Install Line #7 into delay valve (MG0030) and lay over the top of the tire.
- 4) Install Line #6 into new Galfer T-block (MG0025) and lay over the top of the tire.
- 5) Install Line #8 into new Galfer T-block (MG0025). Install lower end line #8 into top banjo bolt hole of right caliper.
- 6) Install line #5 into lower banjo bolt hole of delay valve to the lower bolt hole of the right caliper.

LEFT HAND SIDE

- 1) Install Line #4 (MG0027) into OEM tubing with brass olive. Secure to left front brake hose stay with cable ties. Install lower end Line #4 with double banjo bleeder bolt to top of Line #9, into top of second master cylinder (MG0028).
- 2) Install Line #10 on top of Line #7 with double banjo bolt into the front of the second master cylinder (MG0031). Bottom Line #10 attaches to upper banjo bolt hole of the left caliper (MG0032).
- 3) Install Lower end Line#6 to lower banjo bolt hole left caliper (MG0032)
- 4) Install lower end Line#9 to plunger (MG0029).

(Fig: MG0009 OEM)
Visual look at stock set up to compare with (Fig: MG0009, MG0021, & MG0027) for line# 1, 2, 3, & 4.



(Fig: MG0021) Line# 2 is connected to lower right hard OEM tube with brass olive. Line# 2 goes to right upper delay valve banjo hole. Check with (Fig: MG0009 OEM) for picture overview.

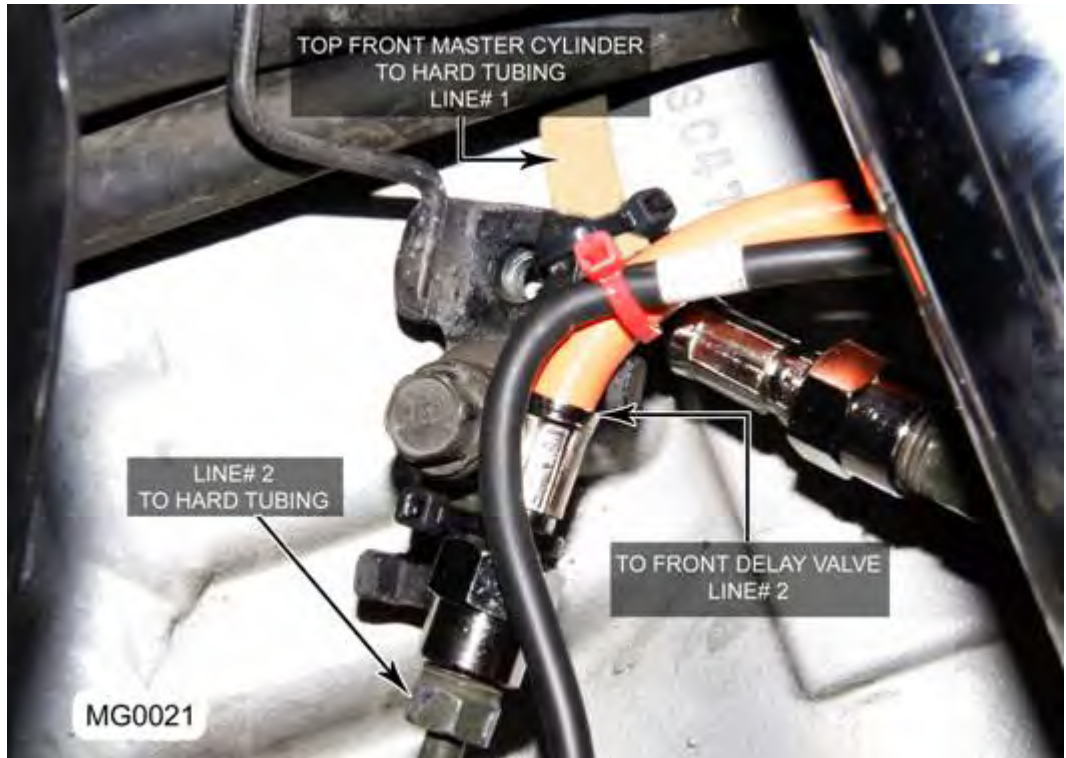

Note: Use brass olive to OEM tube.



(Fig: MG0027) Line# 3 goes to upper Galfer T-block hole from the OEM tube with brass olive. Line# 4 is the farthest left line connected the OEM tube with brass olive. Line# 4 goes to Secondary Master Cylinder on a Double banjo with Line# 9. Check with (Fig: MG0009 OEM) for picture overview.



Note: Use brass olive to OEM tube.



(Fig: MG0022)
Line# 2 is now routed right side and connected to the upper delay valve top hole. Lower Delay valve hole will have Line# 5 going to the right lower caliper hole. Line# 8 is connected to the right upper caliper hole.

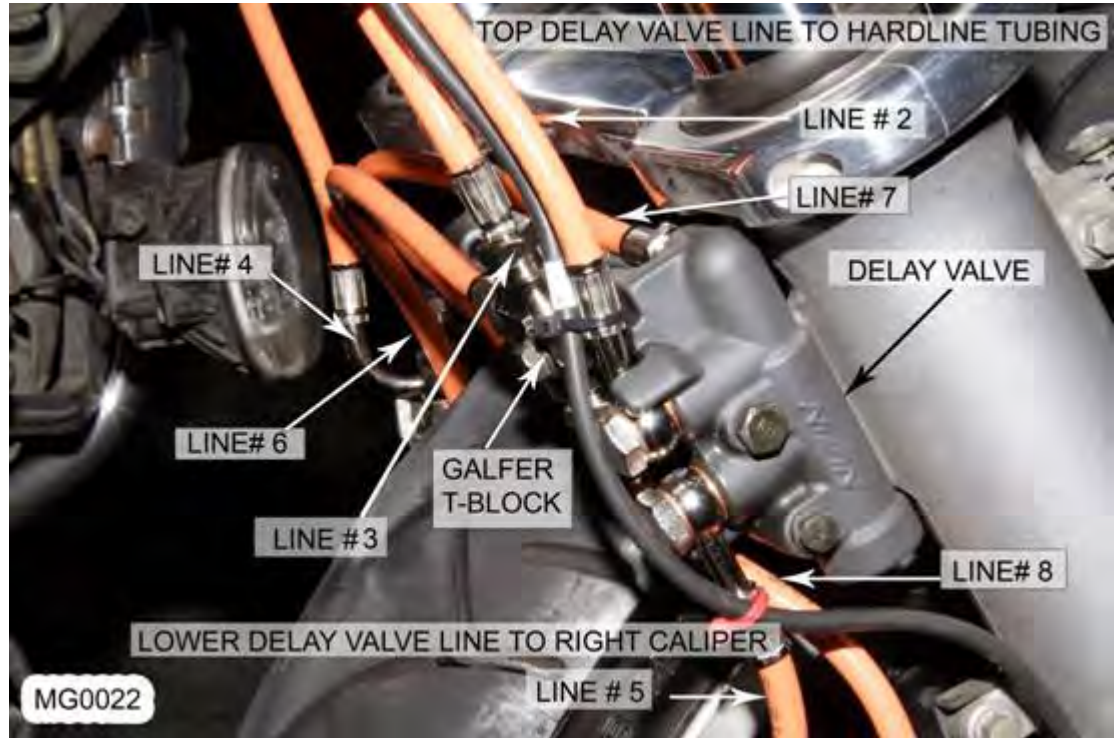

(Fig: MG0023)
Line# 8 is connected to front right top caliper hole, Line# 5 connected to front right bottom caliper hole.

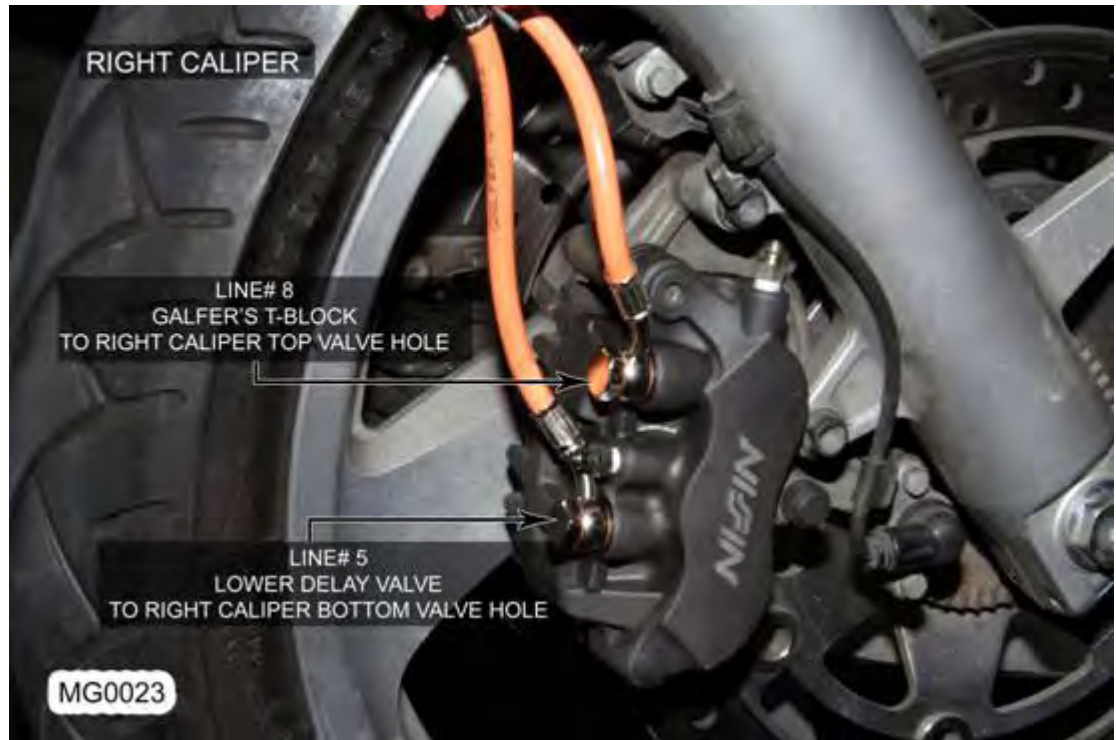

(Fig: MG0025)
Analyzing front right back side fork line routing. Using a Galfer T-block replacing OEM split. Line# 6 connected to Galfer T-block routed to left lower caliper hole. Line# 7 is behind the T-block where it is connected to Delay valve shooting

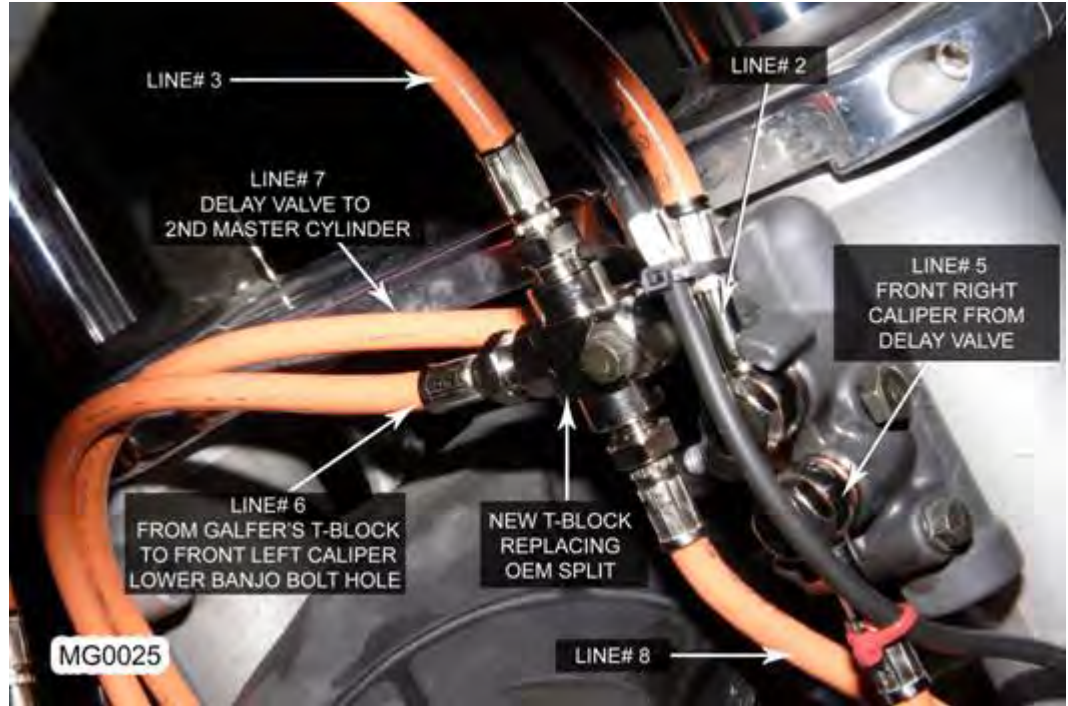

towards left fork. Line# 7 goes to Secondary Master Cylinder using a double banjo on the same double banjo Line# 10 is connected to 2nd Master Cylinder.

(Fig: MG0030)
Picture is showing the back side of Right fork. Behind the new T-block Line# 7 is Connected to Delay Valve and routed to 2nd Master Cylinder (Fig: MG0031)

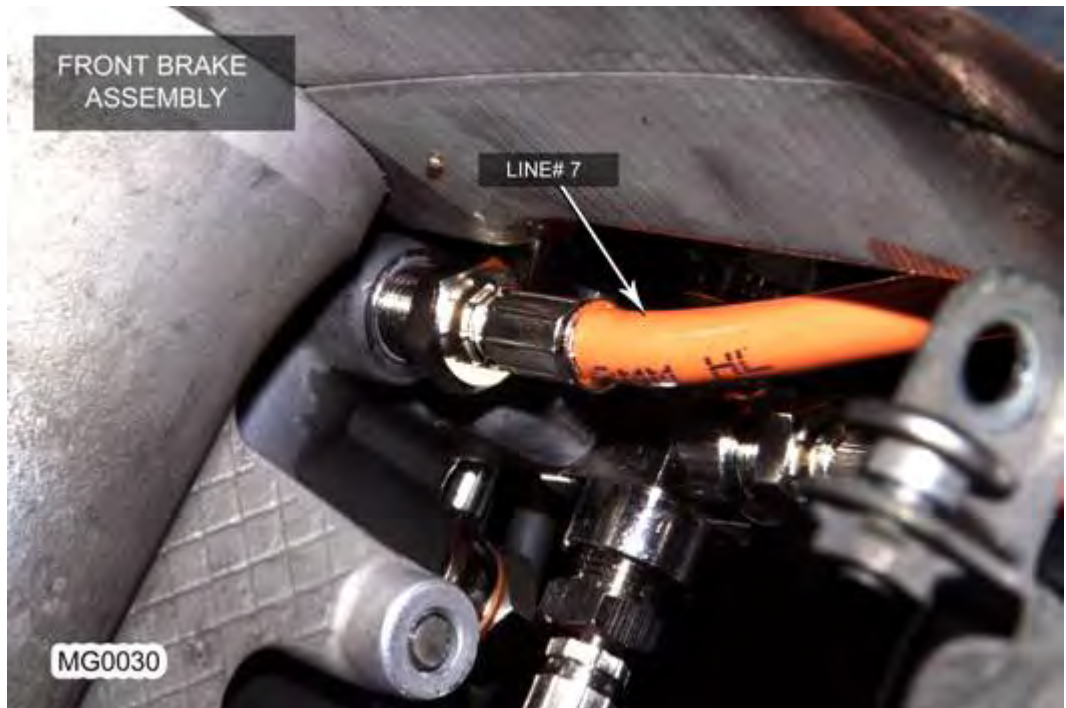

(Fig: MG0031)
Back side of 2nd
Master Cylinder.
Note: Double
banjo connected to
Line# 7 & Line#
10.

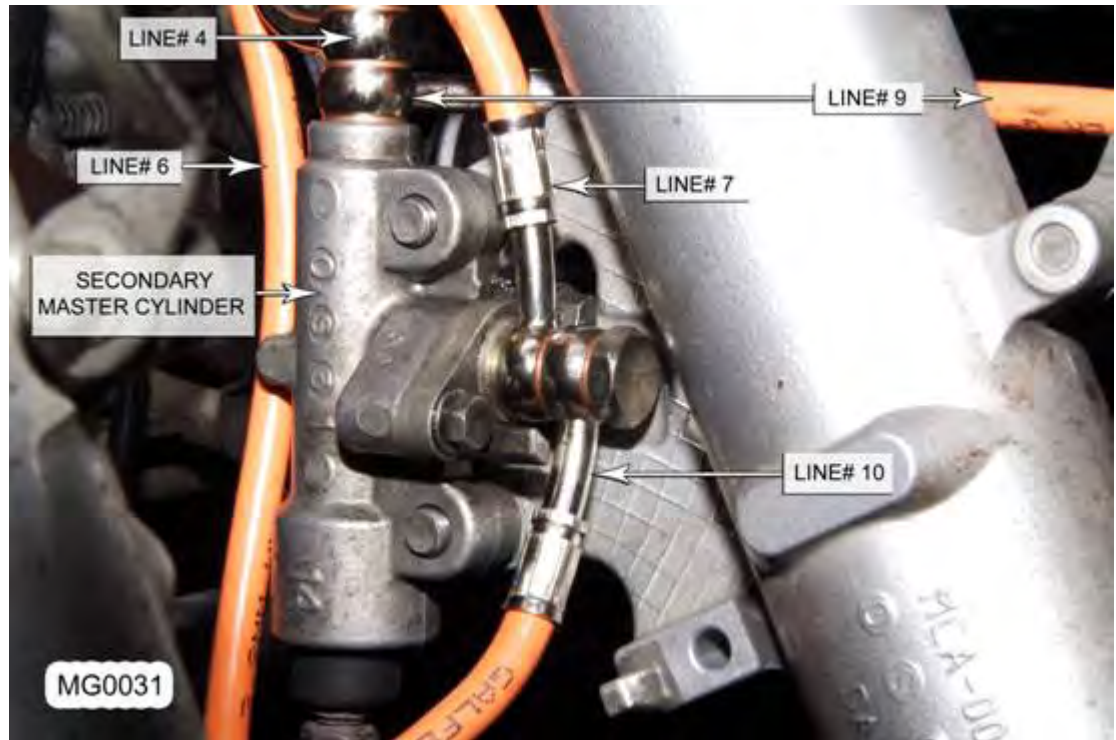

(Fig: MG0032)
Left caliper is
shown with Line#
6 connected to
bottom hole from
Galfer's T-block
(MG0025) see ref.
Line# 10 is
connected to upper
hole from the
backside of the 2nd
Master Cylinder.



(Fig: MG0028)

Line# 4 connected on the top of the 2nd Master Cylinder, where it's connected to the very left upper hard tube. Located in the triple tree. Line# 9 is also connected on an air free double banjo where it connected to the anti dive.

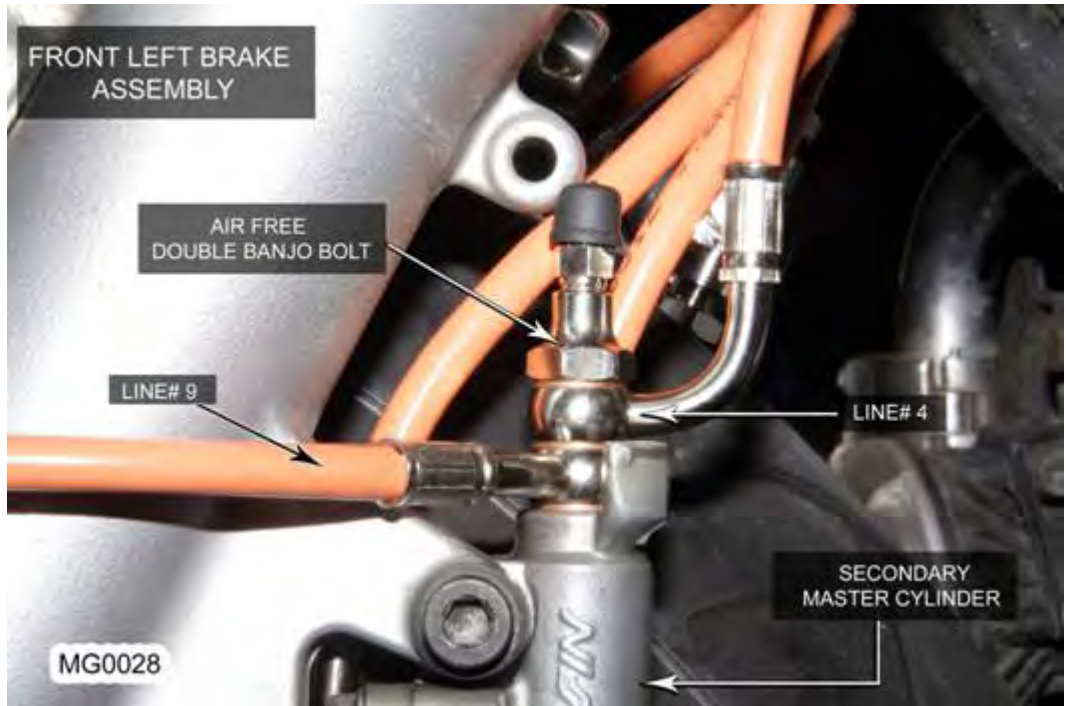

(Fig# MG0029)

Left front fork Line# 9 is connected to Anti Dive plunger from the Secondary Master Cylinder.

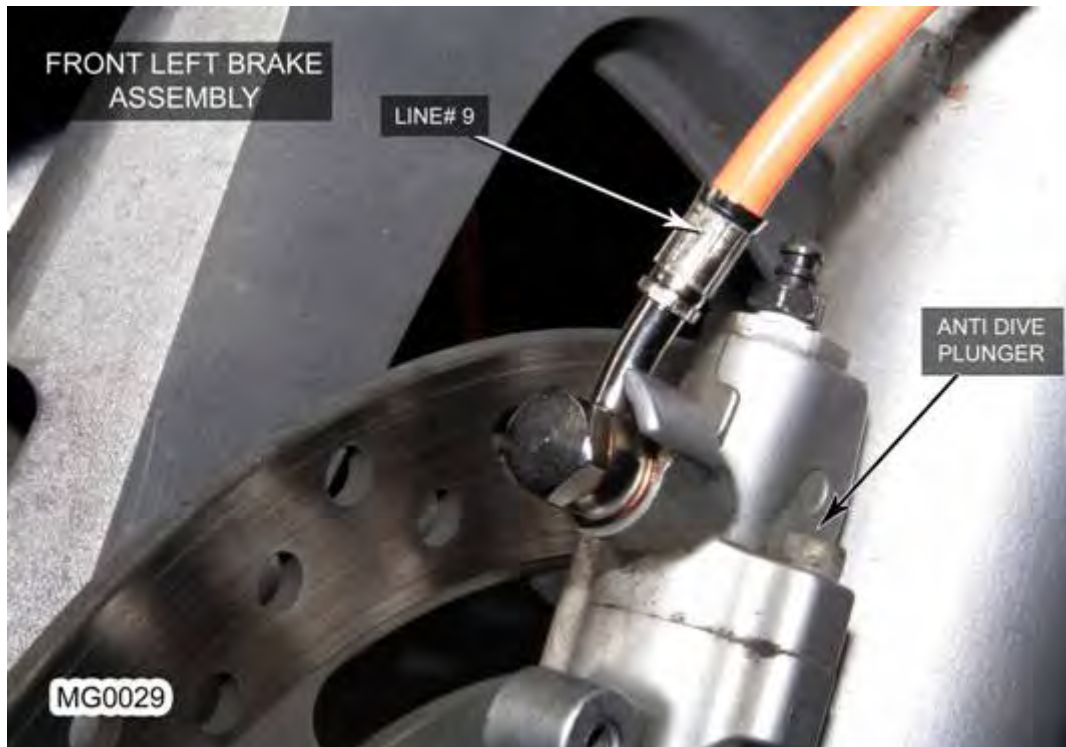

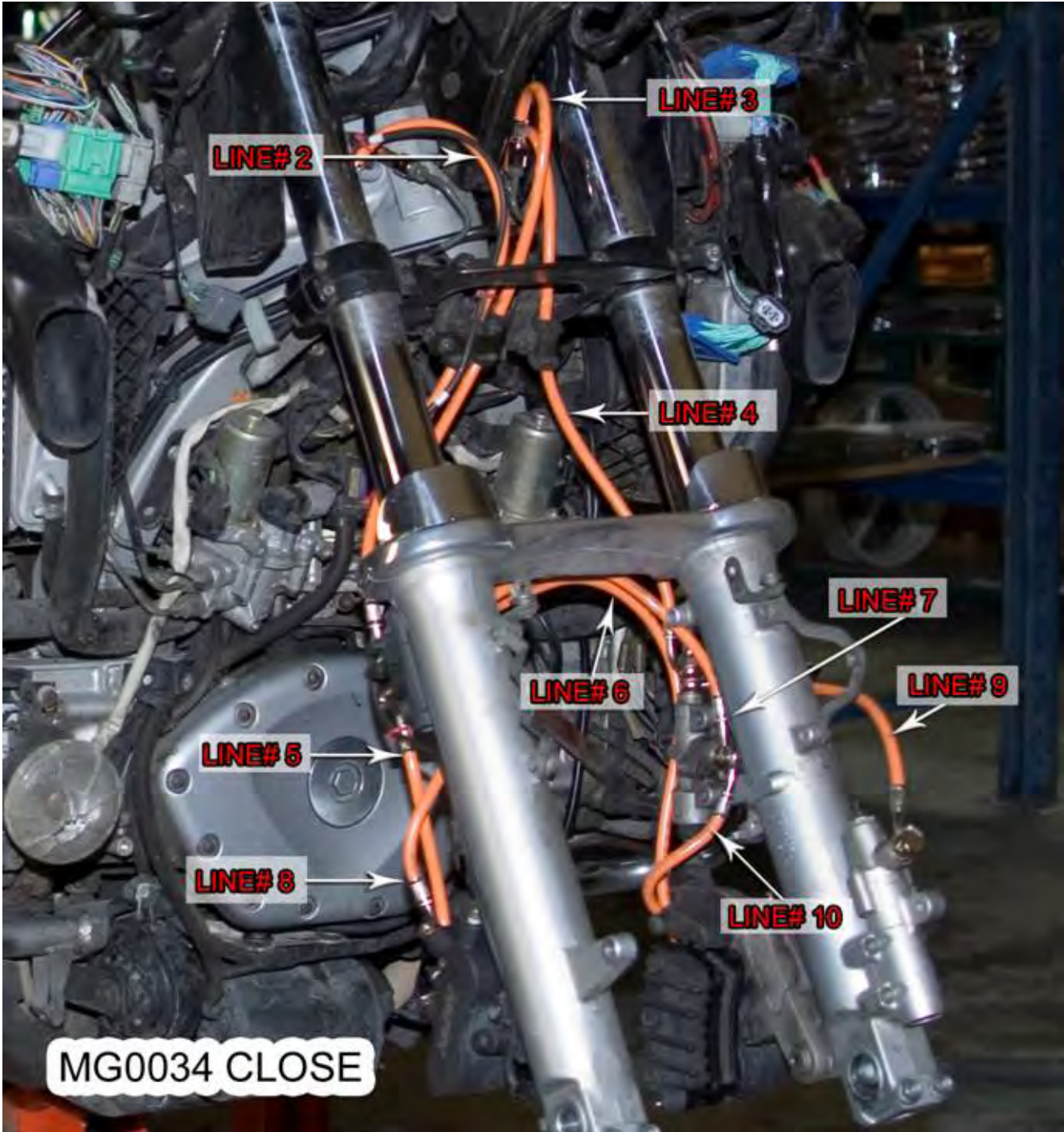

(Fig: MG0034 CLOSE)
Front brake line routing and overview line map.

INSTALLATION OF CLUTCH MASTER CYLINDER LINE

- 1) Install Line #11 into clutch master cylinder (MG0002), following stock routing under left handle bar cover, across top triple clamp retainer (MG0009MOD). Route Line #11 down along left side steering (OEM 1) head, down behind rear ABS modulator (OEM 2) across front engine to slave cylinder.

Note: Remove mounting bolt/coolant drain valve, (OEM 3) pull forward and up to access slave cylinder.

(Fig: MG0002)
Left Top Clutch
Master Cylinder
line# 11 positioned
like shown.



(Fig:
MG0009MOD)
Triple tree area,
Line# 11 is shown
routed left front side
of the bike.



(Fig: OEM1)
Following stock routing under
left handle bar cover, across
top triple clamp retainer



(Fig: OEM2)
Route Line #11 down along
left side steering (OEM 1)
head, down behind rear ABS
modulator (OEM 2) across
front engine to slave cylinder.

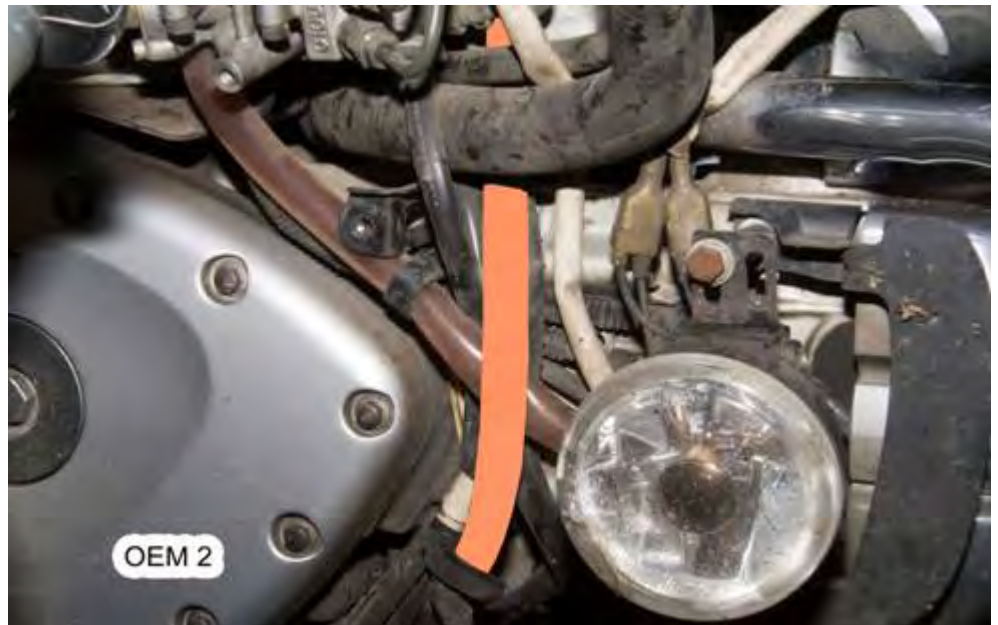

(Fig: OEM3)
Remove mounting
bolt/coolant drain valve, pull
forward and up to access
slave cylinder.



(Fig: MG0003)

Line# 11 shown connected to clutch slave cylinder. In between banjo stopper.



(Fig: MG0034)

Completed front brake line. Lines 1~11 should be installed.

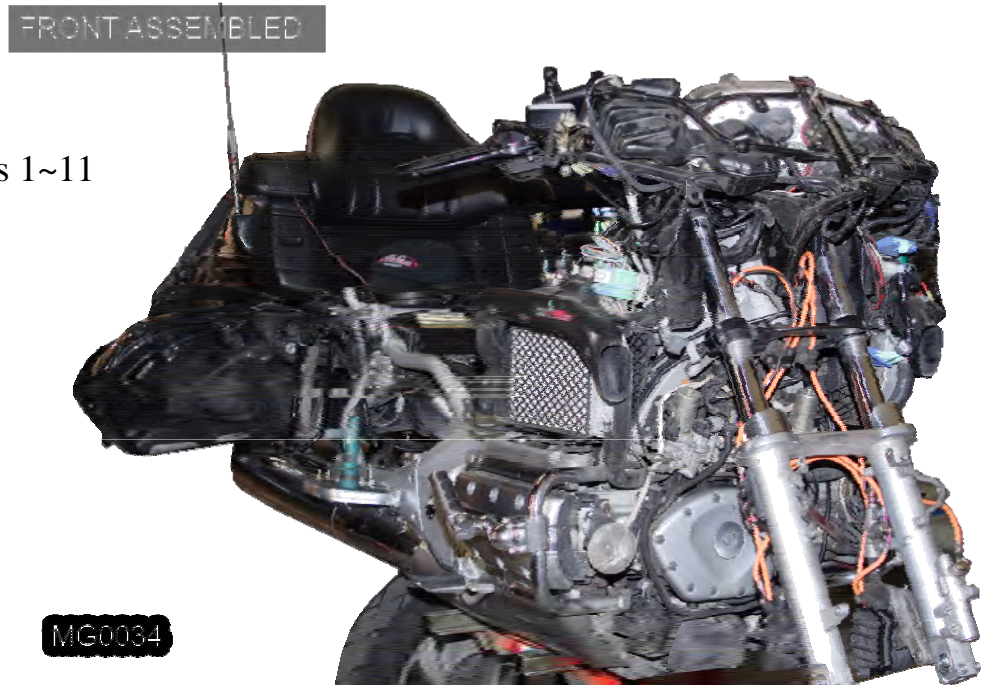

REAR BRAKE LINE INSTALLATION

Note: Prep motorcycle, follow factory manual to remove fuel tank and right hand saddle bag (MG0035).

- 1) Install Line #12 to top of rear master cylinder, (MG0004) routing to OEM tubing, with brass olive, (MG0005), using stock mounting bracket.
- 2) Install Line #13 “inside”, Line #14 “outside” with brass olives to OEM tubing (MG0006). Follow stock line routing (OEM4), (OEM 6) across top of the swing arm, using OEM hose clamps to the rear caliper.
- 3) Line #13 mounts to upper banjo bolt hole in rear caliper. Line #14 mounts to lower banjo bolt hole in rear caliper (MG0007).

Note: Rear wheel speed sensor wire must be secured to brake lines with cable locks, to keep it out of rear wheel.

(Fig: MG0004)
Right middle Rear
Master Cylinder
banjo position as
shown.





(Fig: MG0005)
Line# 12 rear line from master connected to OEM tubing with brass olive right side frame under the seat.

Note: Use brass olive to OEM tube.

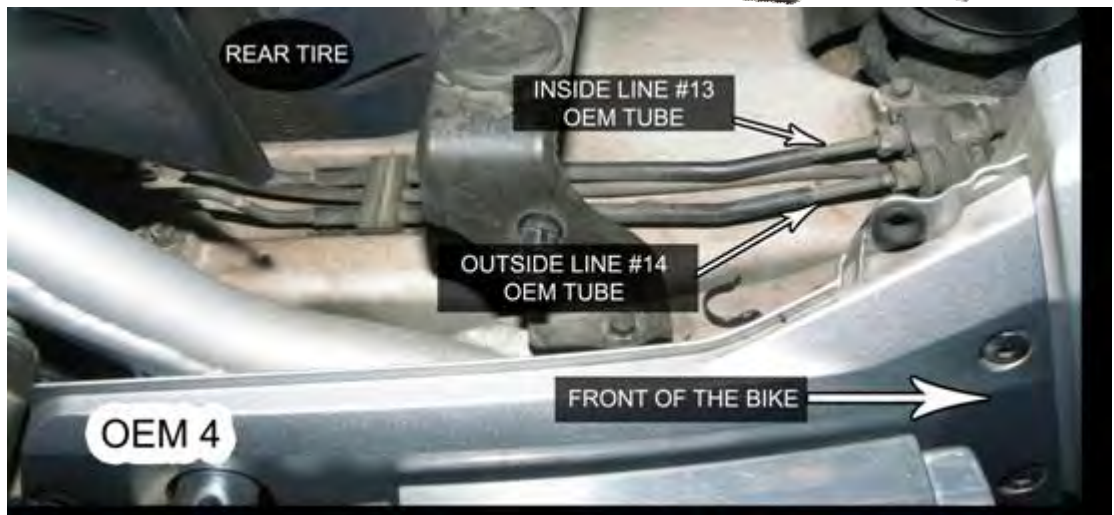

(Fig: OEM 4)
Follow stock line routing (OEM4), (OEM 6) across top of the swing arm, using OEM hose clamps to the rear caliper.

(Fig: OEM 6)
Follow stock line routing (OEM4), (OEM 6) across top of the swing arm, using OEM hose clamps to the rear caliper.

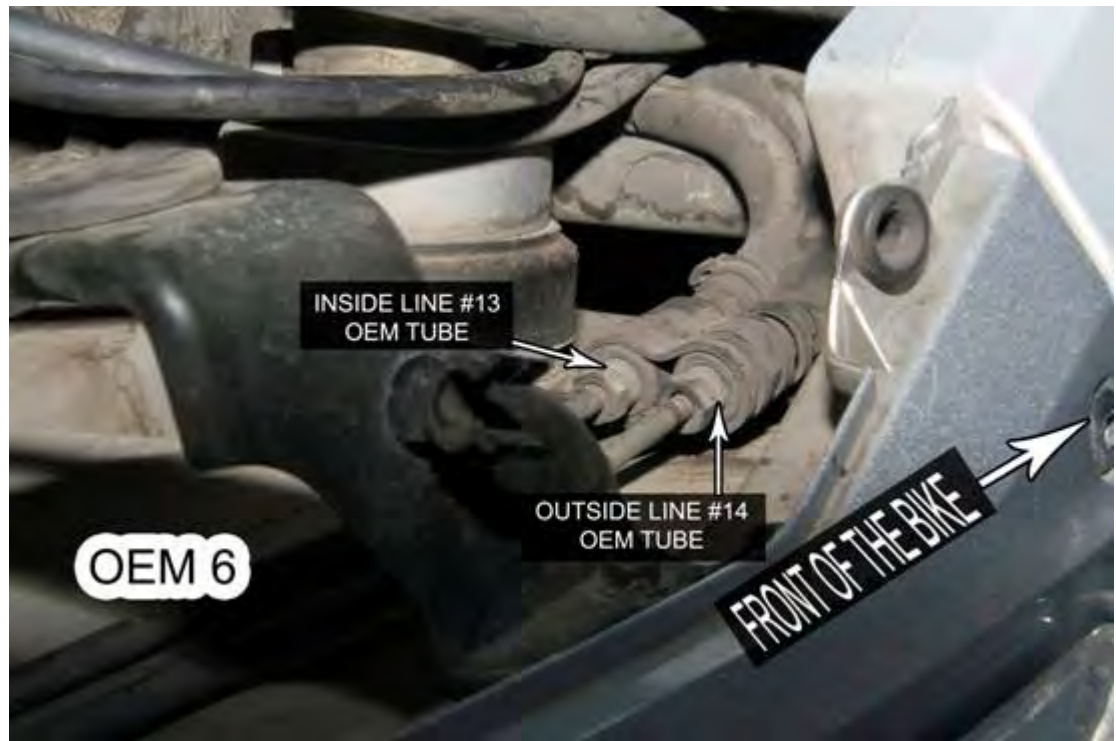

(Fig: MG0006)
Line# 13 & 14 are connected to the OEM tubing with brass olives. Location is between swing arm and frame cross member.

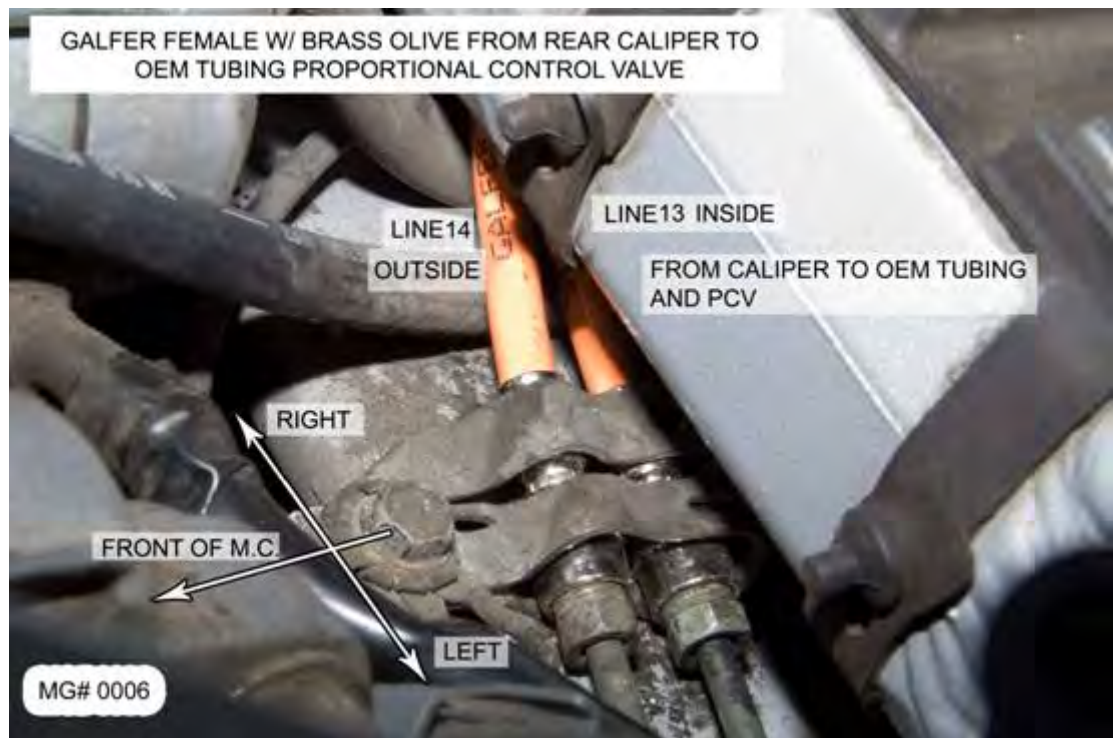

Note: Use brass olive to OEM tube.



(Fig: MG0007)
Line# 13 & 14 are
connected to right
rear caliper.

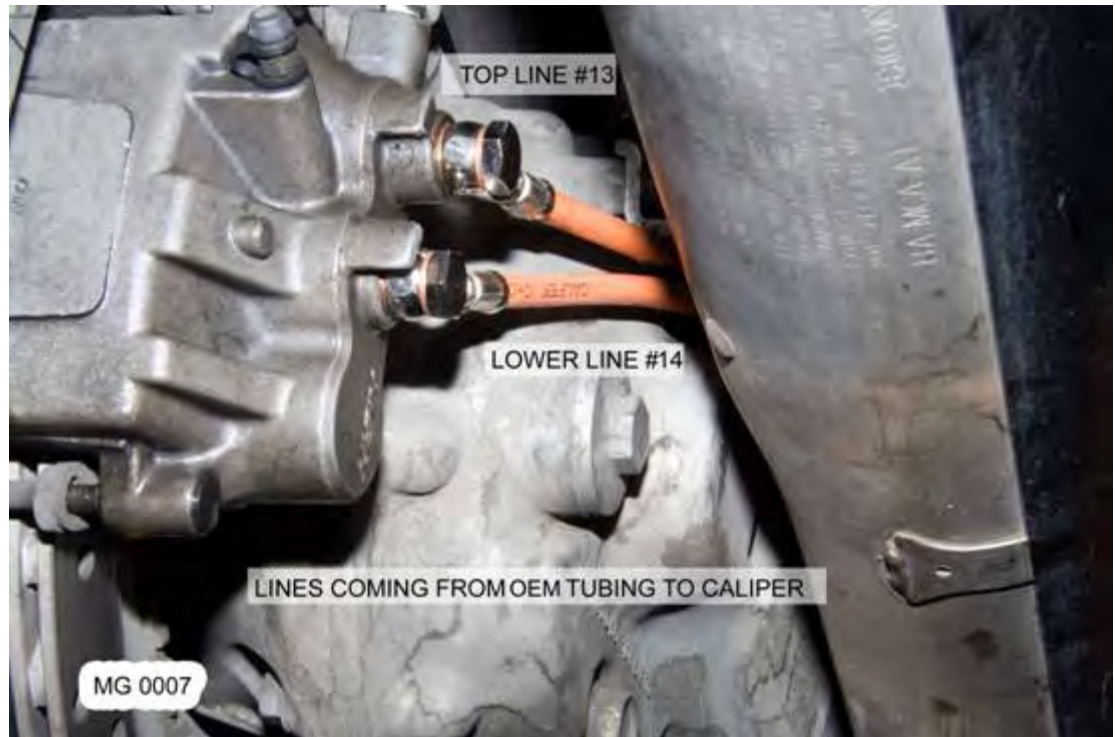

YOU ARE NOW READY TO FOLLOW...WORD FOR WORD...THE FACTORY
PROCEDURE FOR BLEEDING THE SYSTEM. A COPY OF THE HONDA
PROCEDURE IS INCLUDED WITH THESE DIRECTIONS.

All banjos and Double banjos are torque to 12-15 ft/lbs.

A copy of the factory instructions (Fig: OEM BLEED) has been included with this
kit on how to properly and safely drain, fill and bleed the brake fluid from the brake
systems. Follow the bottom directions closely and remove the fluid according to the
instructions. Dispose of the old fluid properly---
DO NOT REUSE.

8 Parts included in the kit

1. Single Banjo Bolt – 13
2. Double Banjo Bolt – 1
3. Air Free Double Banjo Bolt – 1
4. Crush Washer – 32
5. Brass Olive – 7
6. T-Block – 1
7. SS Lines – 14
8. Instruction pg – 23

PEDAL BRAKE LINE FULL FILLING/ AIR BLEEDING

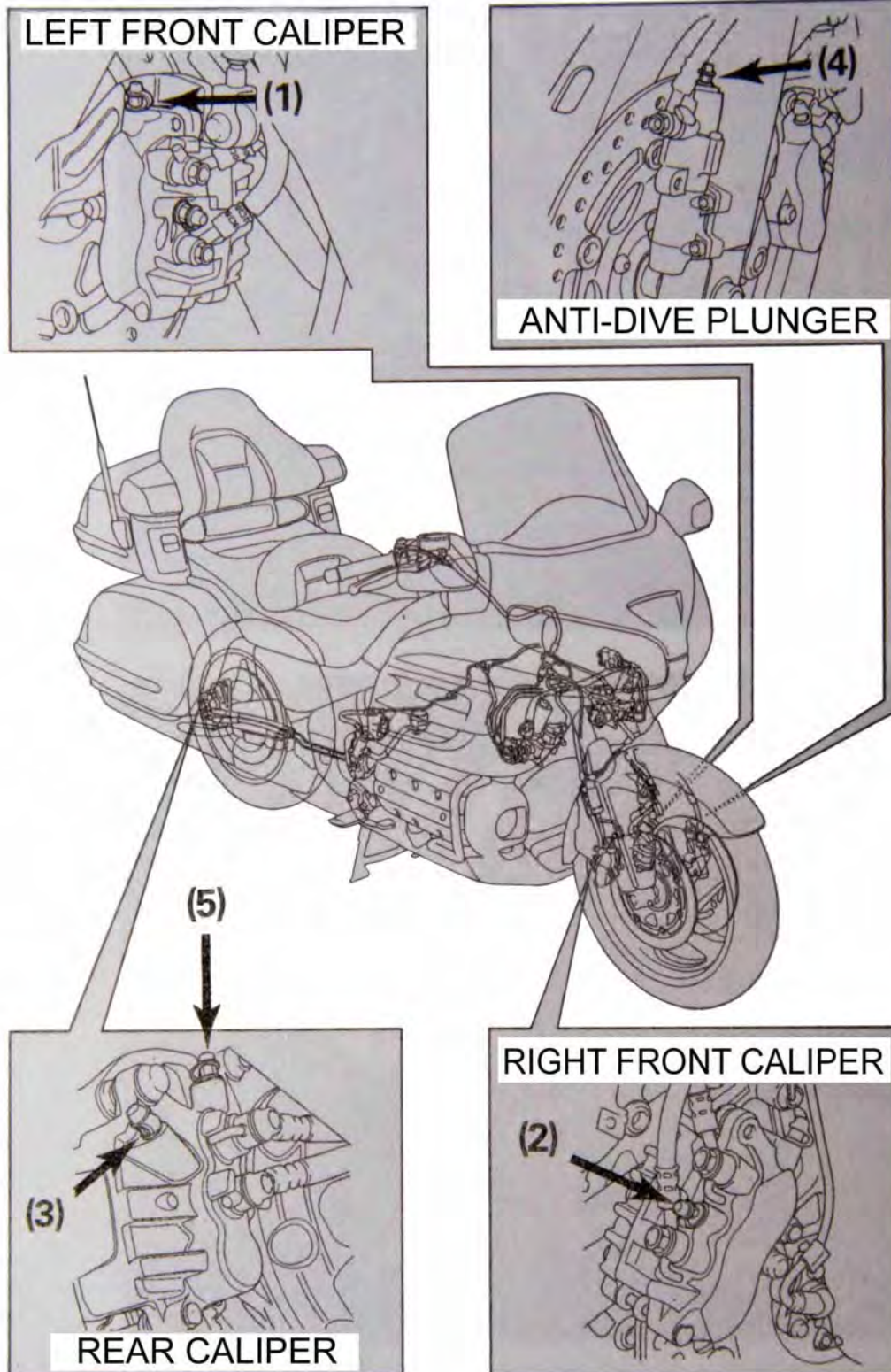

NOTE: BEFORE PERFORMING, HAVE AT LEAST 16.9 OZ OR 500CC OF BRAKE FLUID.

Before performing this service, have at **LEAST** 500cc DOT 4 brake fluid. Feed fluid and bleed air from the pedal brake line in the following sequence.

- (1) Left front caliper upper side bleed valve. (Fig: Principles of Front Brake)
- (2) Right front caliper lower side bleed valve (Fig: Principles of Front Brake)
- (3) Rear caliper lower side bleed valve (Fig: Principles of Rear Brake)
- (4) Anti-dive plunger bleed valve (Fig: Principles of Rear Brake)
- (5) Rear caliper upper side bleed valve (Fig: Principles of Rear Brake)

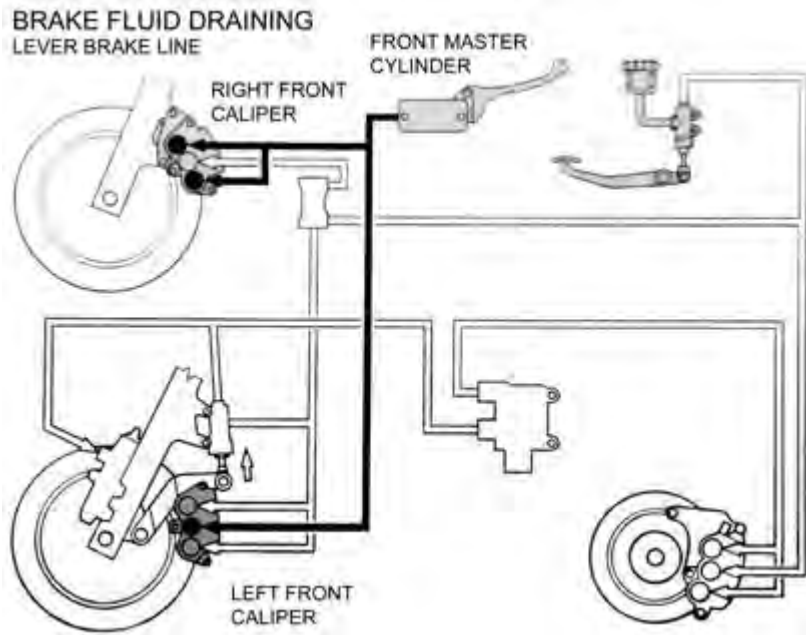

PEDAL BRAKE LINE

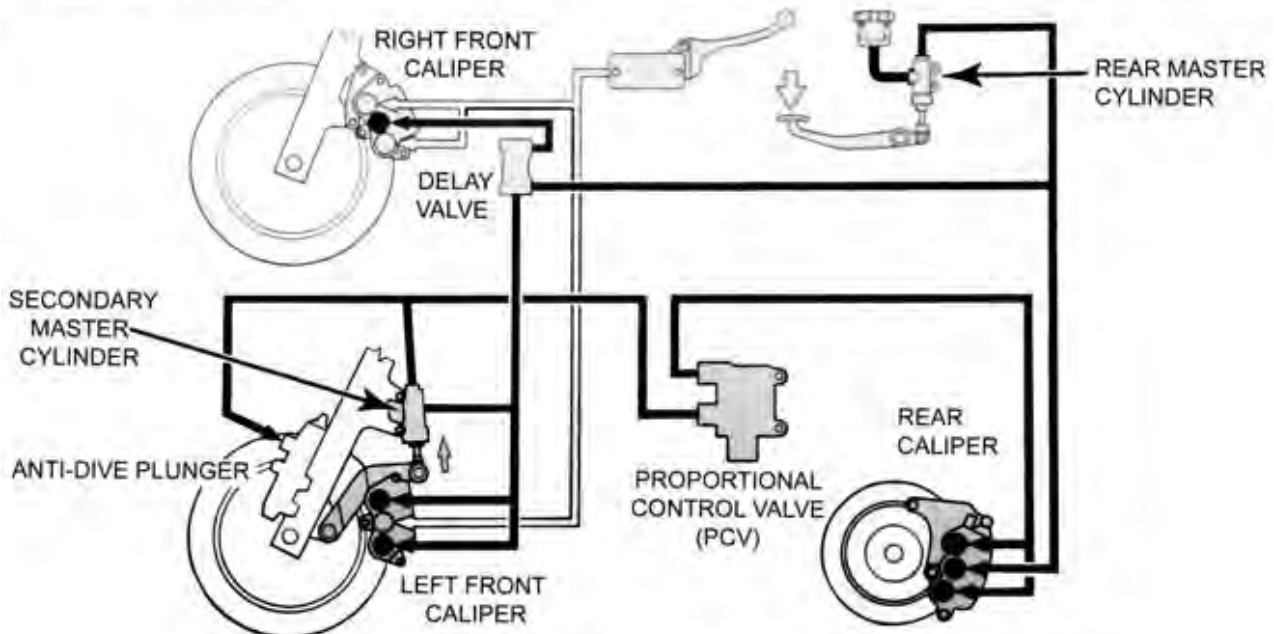

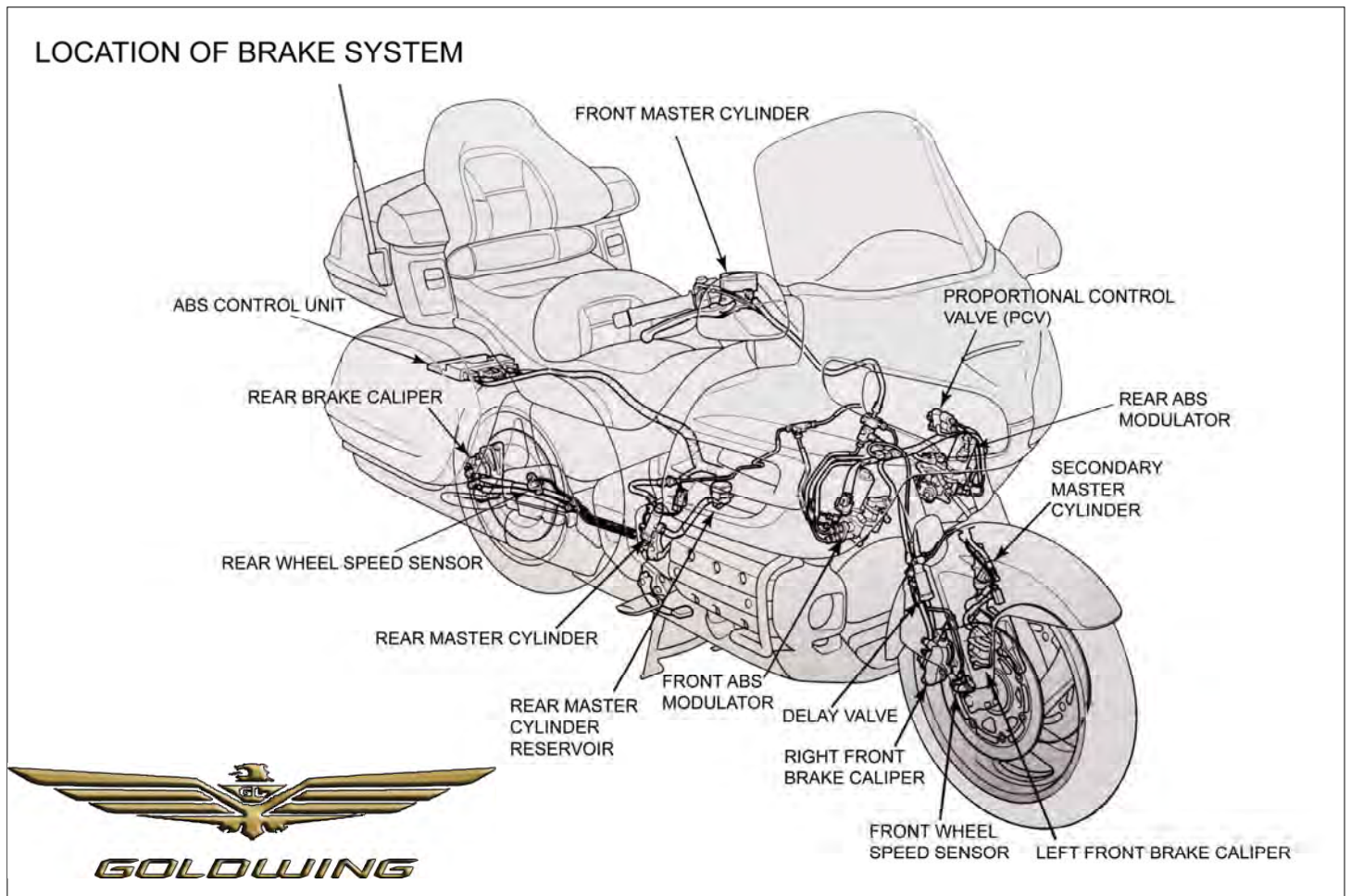

(Fig: Location of Brake System)

This is provided as a Legend guide, technical name and location on bike.